

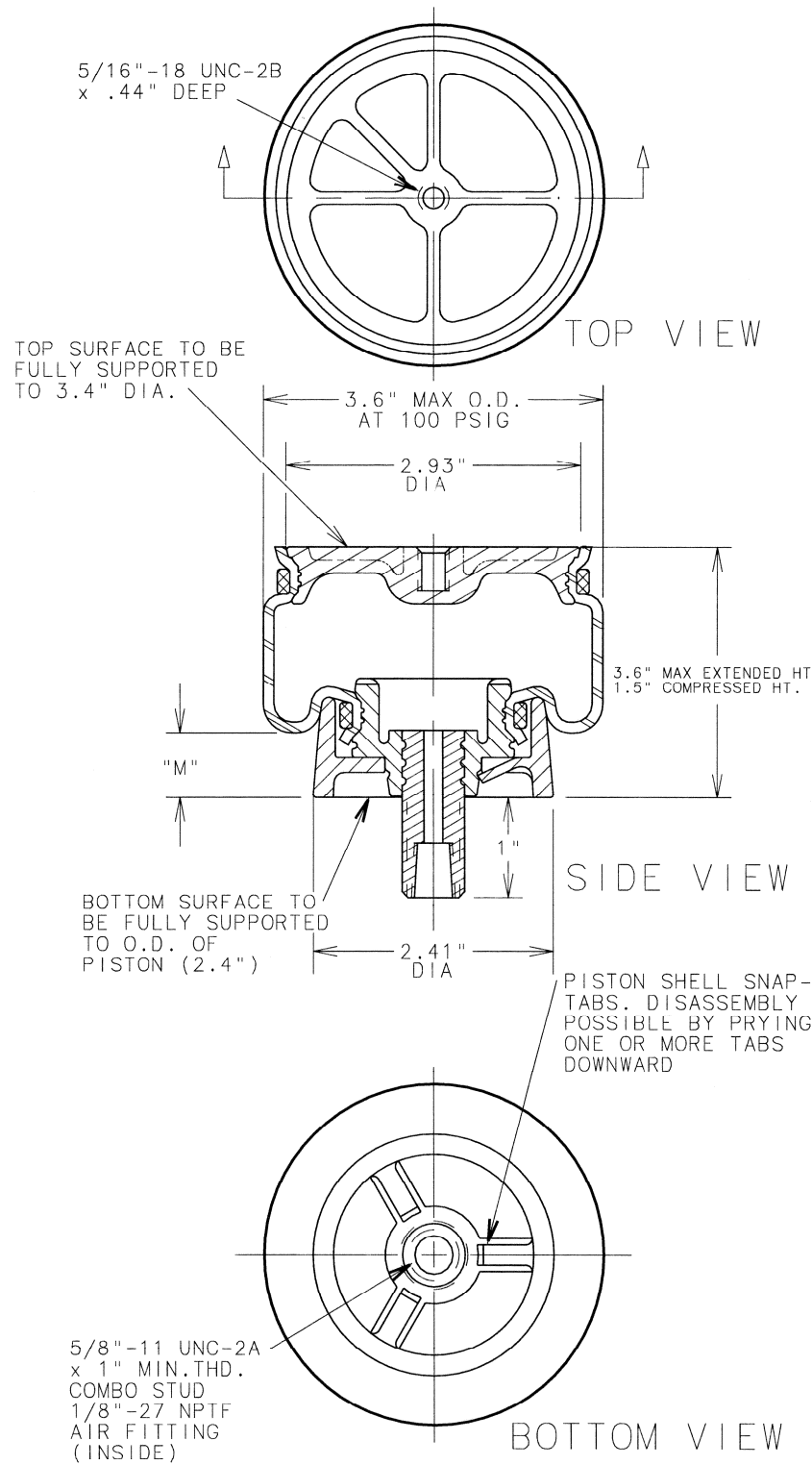

1S3-013



ASSEMBLY NUMBER	ELASTOMER	AIR FITTING	BUMPER INCLUDED
1S3-013	WINGPRENE®	1/8"-27 NPTF COMBO STUD	NO

SPRING FEATURES:

- LOAD RANGE (ISOLATOR).....90-580 lb
- DESIGN HEIGHT RANGE (ISOLATOR).....2.0-3.0 in
- USEABLE STROKE (ACTUATOR).....2.1 in
- ASSEMBLY WEIGHT.....0.6 lb
- FORCE TO COMPRESS AT 0 PSIG.....6 lb
- LIGHT WEIGHT END RETAINERS (REINFORCED THERMOPLASTIC)
- ABUSE RESISTANT STEEL STUD

RECOMMENDED MAX. TORQUE VALUES

5/16"-18 UNC BLIND TAP	5/8"-11 UNC COMBO STUD	1/8"-27 UNC AIR FITTING
30-50 in-lb 2.5-4 ft-lb	300 in-lb 25 ft-lb	180 in-lb 15 ft-lb

NOTE: SEE GUIDELINES FOR PROPER APPLICATION OF THIS PRODUCT

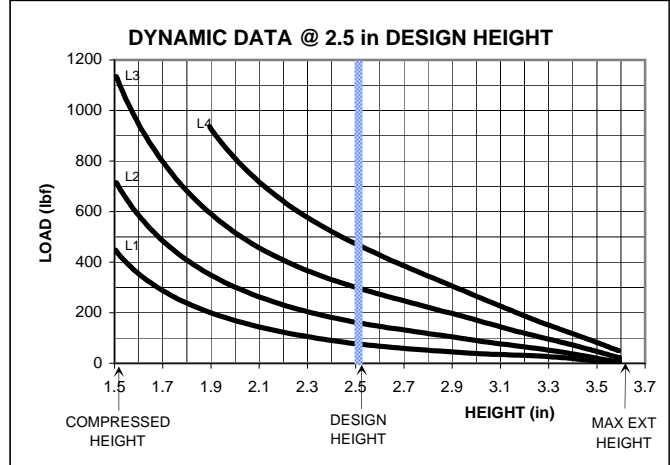
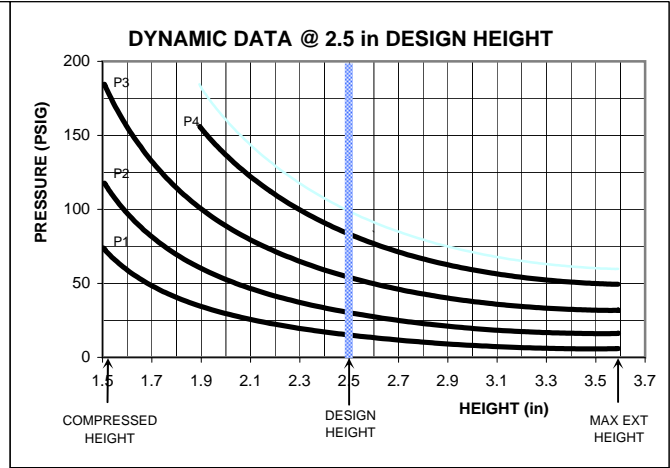
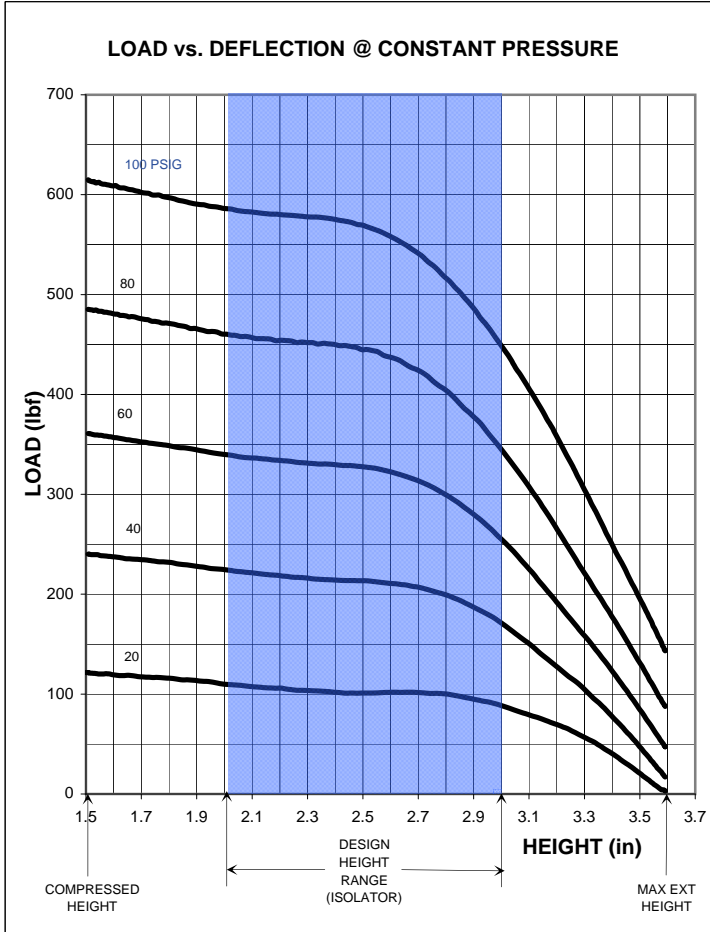

****NOTE: MAXIMUM INFLATION PRESSURE IS 100 PSIG. MAXIMUM JOUNCE PRESSURE IS 200 PSIG. IF YOUR APPLICATION WILL EXCEED THESE LIMITS, CONSULT A GOODYEAR ENGINEERED PRODUCTS AIR SPRINGS REPRESENTATIVE FOR APPLICATION ASSISTANCE.**

CONSTANT PRESSURE CHARACTERISTICS

Assembly Height (in)	Meniscus Height "M" Dim. @ 100 PSIG	Volume @ 100 PSIG (in ³)	Nominal Force (lb)				
			@ 20 PSIG	@ 40 PSIG	@ 60 PSIG	@ 80 PSIG	@ 100 PSIG
3.6	1.03	14.8	10	30	40	80	120
3.5	1.02	14.3	20	50	90	140	180
3.0	0.98	12.3	90	170	260	340	440
2.5	0.78	9.6	100	220	320	440	560
2.0	0.45	6.5	110	230	340	460	580
1.5	0.16	3.4	120	240	360	480	600

DYNAMIC CHARACTERISTICS

Design Height (in)	Load (lb)	Pressure (PSIG)	Spring Rate (lb/in)	Natural Frequency	
				cpm	Hz
3.0	80	21	160	236	3.93
	160	43	300	230	3.83
	300	77	495	223	3.72
2.5	80	18	145	224	3.73
	160	35	225	202	3.37
	300	61	370	194	3.23
2.0	460	88	520	191	3.18
	80	17	190	258	4.30
	160	34	300	231	3.85
	300	60	470	216	3.60
	460	85	610	208	3.47
	570	100	720	207	3.45

The GOODYEAR (and Winged Foot Design) trademark is used by Veyance Technologies, Inc. under license from The Goodyear Tire & Rubber Company. Goodyear Engineered Products are manufactured and sourced exclusively by Veyance Technologies, Inc. or its affiliates. The following trademarks are licensed to Veyance Technologies, Inc. by The Goodyear Tire & Rubber Company, including Compass, Eagle Pd, Flexten, Gatorback and GY Metric. ©2008 Veyance Technologies, Inc. All Rights Reserved.