

NOTE: All Assembly Order Numbers are for bead plate parts unless noted otherwise.

	Description	Assembly Order No.
Style 110	Blind nuts, 1/4 BSP	W01-M58-6145
	Socket head aluminum bead rings (bolts, nuts, washers not included—use M6 cap screws)	W01-358-0112
Two Ply Bellows	Rubber bellows only	W01-358-0100
Assembly weight.....		1.36 kg.
Force to collapse to minimum height (@ 0 BAR)		36 N.

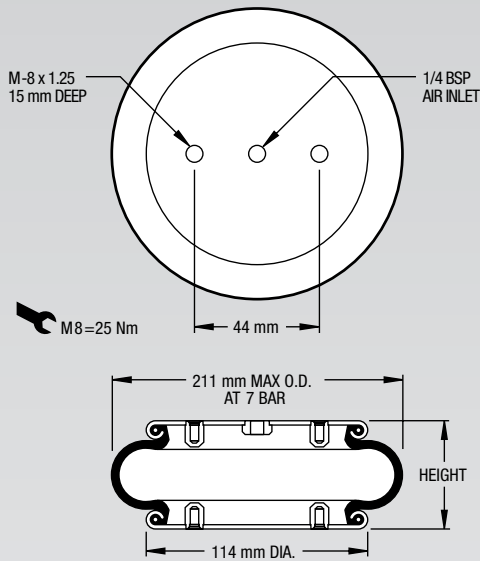

NOTE: A bead plate part is shown. This part is also available with bead rings. Bolts are not included. See pages 8-10 for explanation.

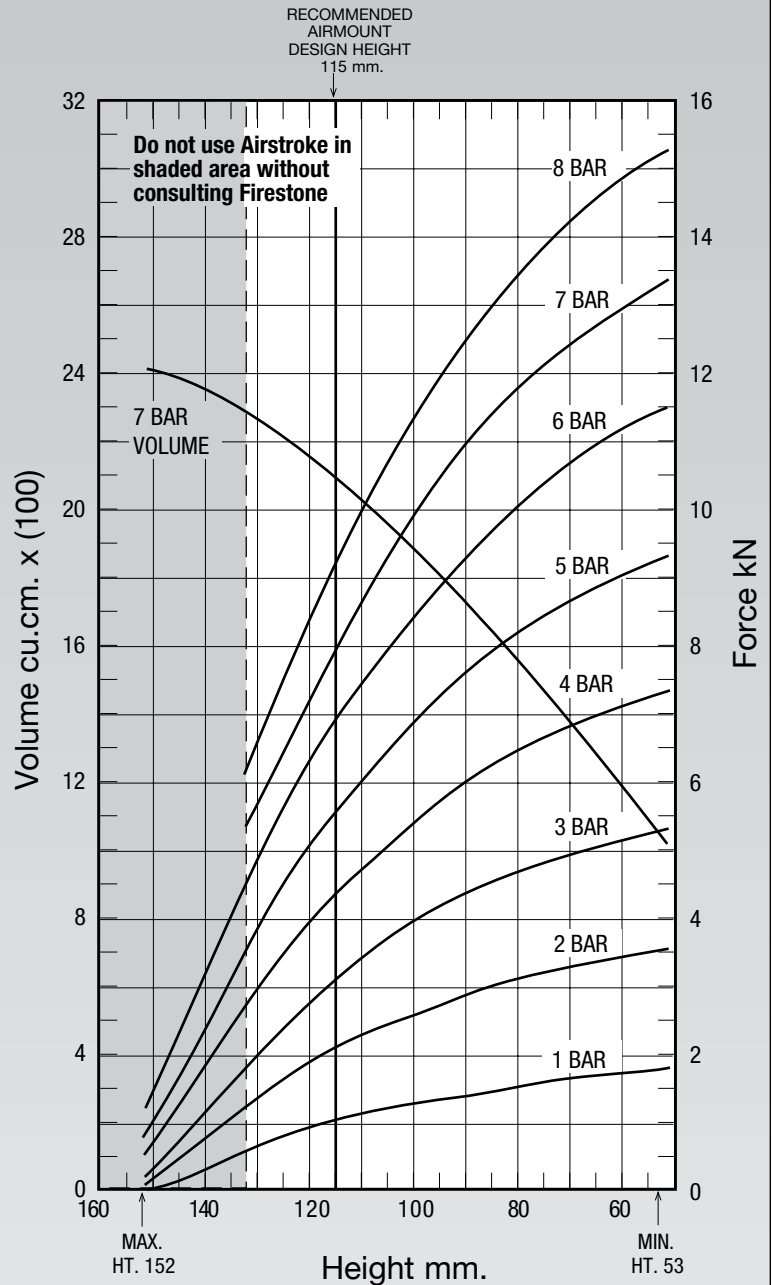

See page 12 for instructions on how to use chart.

Gauge Pressure (BAR)	Load (kN)	Spring Rate (kN/m)	Natural Frequency Hz
3	3.10	99	2.82
4	4.29	127	2.72
5	5.48	157	2.67
6	6.78	189	2.63
7	7.92	218	2.62

Assembly Height (mm)	Volume @ 7 BAR (cu cm)	EFF Area @ 7 BAR (cm**2)	kN Force				
			@ 3 BAR	@ 4 BAR	@ 5 BAR	@6 BAR	@7 BAR
130	2268	80	2.03	2.90	3.75	4.74	5.58
120	2167	103	2.76	3.86	4.95	6.14	7.18
110	2037	123	3.41	4.68	5.96	7.36	8.61
100	1898	140	3.92	5.34	6.78	8.36	9.78
90	1733	154	4.33	5.92	7.49	9.23	10.80
80	1568	166	4.64	6.39	8.08	9.94	11.62
70	1379	176	4.89	6.77	8.58	10.55	12.30
60	1198	184	5.09	7.05	8.97	11.03	12.85