

Description		Assembly Order No.
Style 121	Ribbed neck aluminum bead rings, 17/8 bolts, nuts, washers	W01-358-7197
Two Ply Bellows	Rubber bellows only	W01-358-5135
	Rolled Plate Assembly*, 1/2 blind nuts, 3/4 NPT	W01-358-7272
Assembly weight.....		15.3 lbs.
Force to collapse to minimum height (@ 0 PSIG)		20 lbs.

Recommended Design Position Static Pressure 0-100 psi
RECOMMENDED AIRMOUNT DESIGN HEIGHT 5.0 INCHES

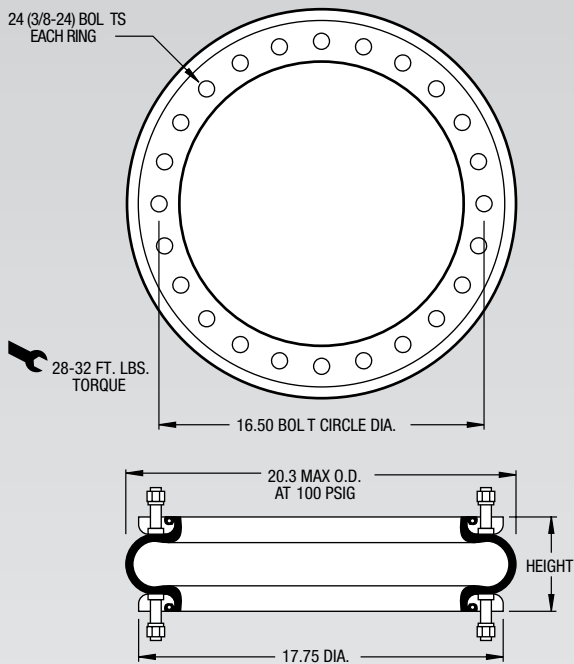

NOTE: A bead ring part is shown. This part is also available with rolled plates. See page 11 for explanation.

*Increase the minimum height by .70 inch. Add .70 inch to the height (bottom axis) before reading loads.

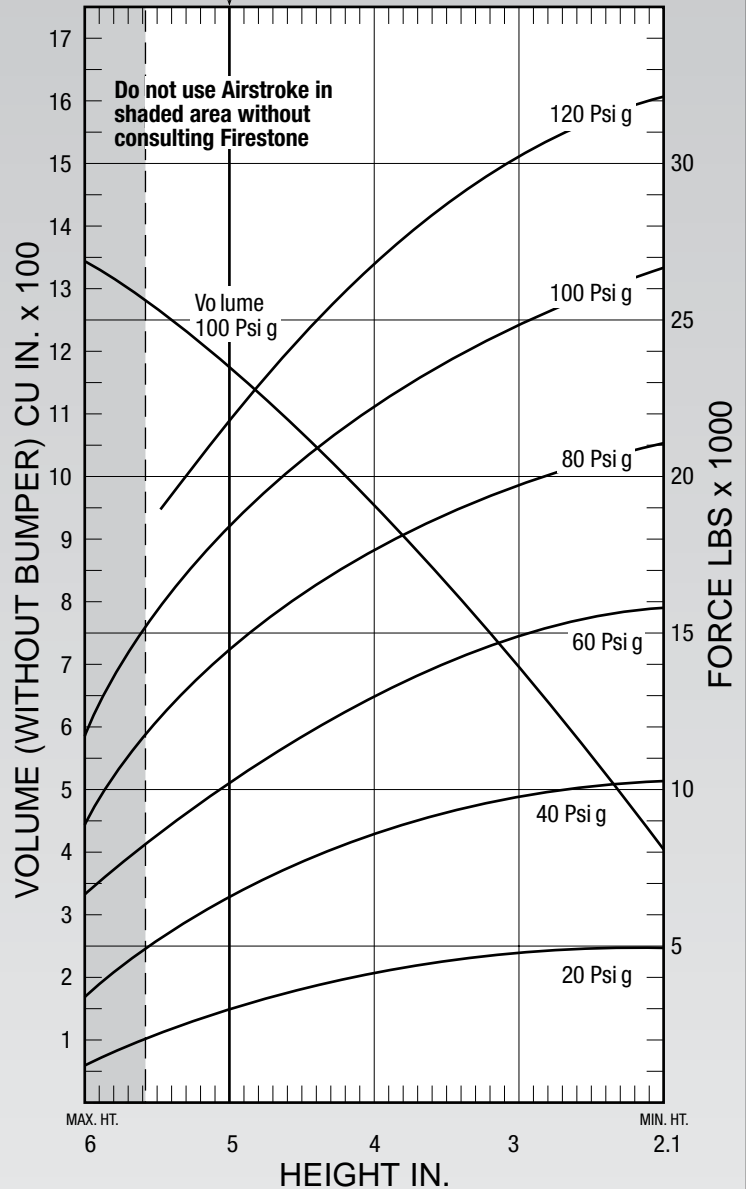

See page 12 for instructions on how to use chart.

Volume @ 100 PSIG = 1,154 in ³			Natural Frequency	
Gage Pressure (PSIG)	Load (lbs.)	Spring Rate (lbs./in.)	CPM	HZ
			40	6,450
60	10,300	6,441	148	2.47
80	14,450	8,312	142	2.37
100	18,450	10,086	139	2.31

Assembly Height (in.)	Volume @ 100 PSIG (in ³)	Pounds Force				
		@20 PSIG	@40 PSIG	@60 PSIG	@80 PSIG	@100 PSIG
5.0	1,154	2,830	6,450	10,300	14,450	18,450
4.0	935	4,100	8,540	13,070	17,550	22,180
3.0	682	4,760	9,690	14,750	19,600	24,690