

Description		Assembly Order No.
Style 138-1.5	Ribbed neck aluminum bead rings (equal spacing),	
Two Ply	1 7/8 bolts, nuts, washers	W01-358-7737
High Strength	?	W01-358-7734
Bellows	Rubber bellows only	W01-358-0147
Assembly weight.....		23.8 lbs.
Force to collapse to minimum height (@ 0 PSIG) ...		150 lbs.

Recommended Design Position Static Pressure 0-100 psi

RECOMMENDED AIRMOUNT DESIGN HEIGHT 6.0 INCHES

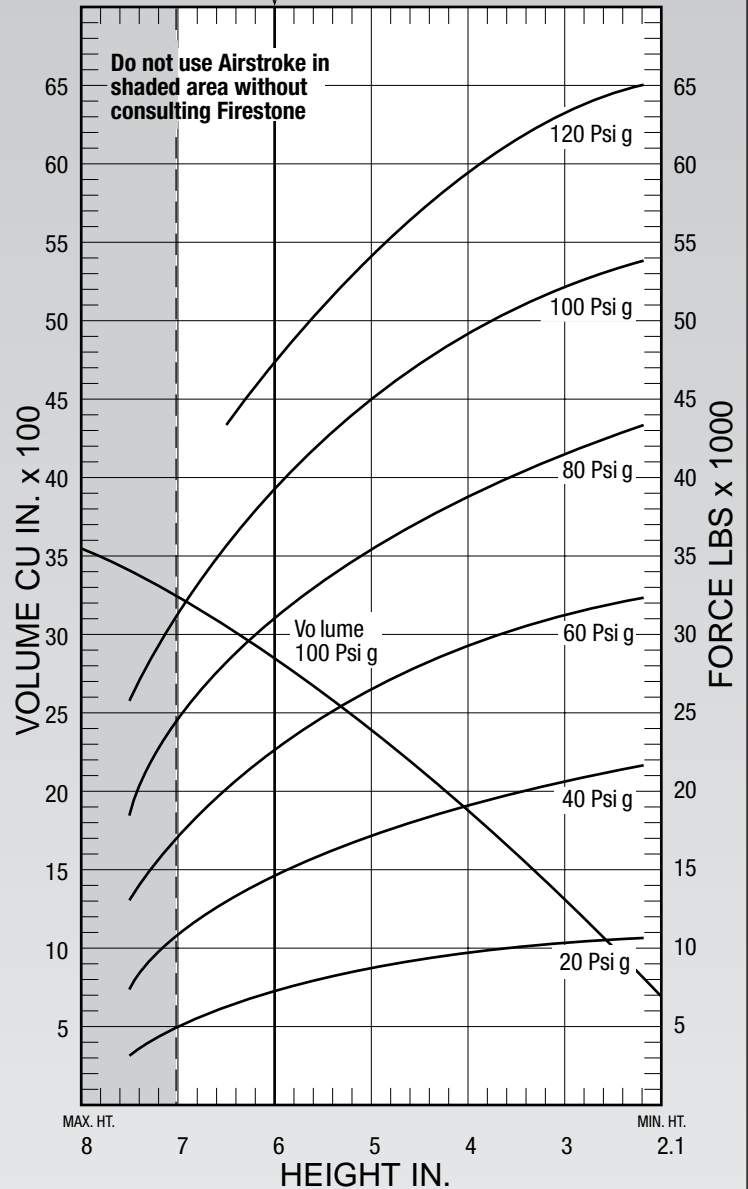
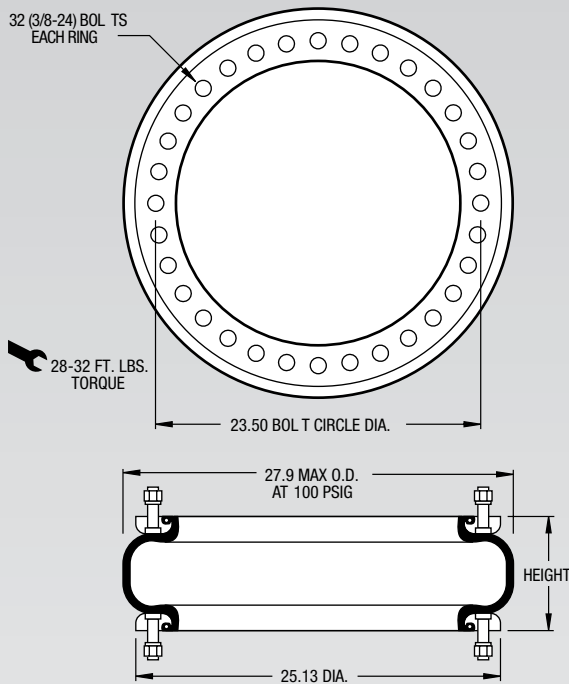

See page 12 for instructions on how to use chart.

Dynamic Characteristics at 6.0 in. Design Height (Required for Airmount isolator design only)				
Volume @ 100 PSIG = 2,846 in ³			Natural Frequency	
Gage Pressure (PSIG)	Load (lbs.)	Spring Rate (lbs./in.)	Natural Frequency	
			CPM	HZ
40	15,020	6,932	128	2.13
60	23,040	10,353	125	2.10
80	31,240	12,979	121	2.02
100	39,570	15,786	119	1.98

Force Table (Use for Airstroke™ actuator design)						
Assembly Height (in.)	Volume @ 100 PSIG (in ³)	Pounds Force				
		@20 PSIG	@40 PSIG	@60 PSIG	@80 PSIG	@100 PSIG
7.0	3,227	5,290	10,830	17,450	24,320	31,630
6.0	2,846	7,290	15,020	23,040	31,240	39,570
5.0	2,402	8,610	17,220	26,410	35,580	44,680
4.0	1,906	9,760	19,630	29,320	39,260	49,620
3.0	1,376	10,200	20,840	31,560	41,930	53,010