

# 148-1

# Firestone

# AIRSTROKE™ ACTUATORS

# AIRMOUNT™ ISOLATORS

	Description	Assembly Order No.
Style 148-1	Ribbed neck aluminum bead rings (equal spacing), 1 7/8 bolts, nuts, washers	W01-358-9601
High Strength Bellows	Rubber bellows only	W01-358-1021
Assembly weight.....		72.9 lbs.
Force to collapse to minimum height (@ 0 PSIG) ...		310 lbs.

Recommended Design Position Static Pressure 0-100 psi

RECOMMENDED AIRMOUNT DESIGN HEIGHT 5.5 INCHES

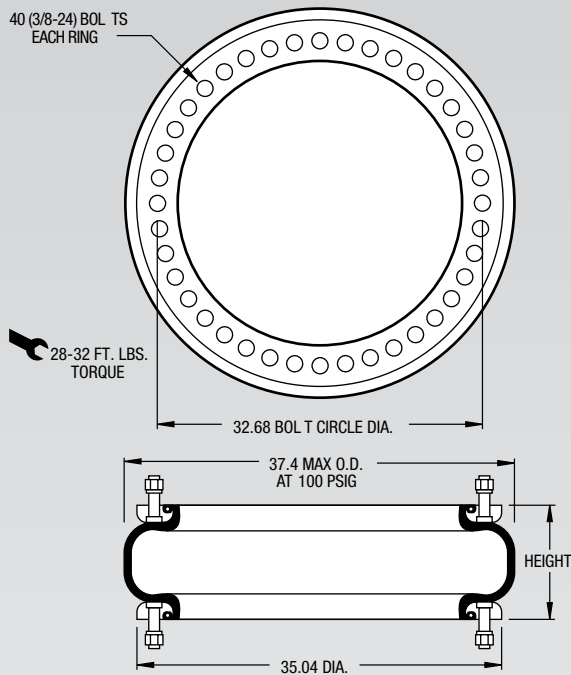

**NOTE:** The effective length of the 1 7/8 bolt is 1.05" in this bead ring.

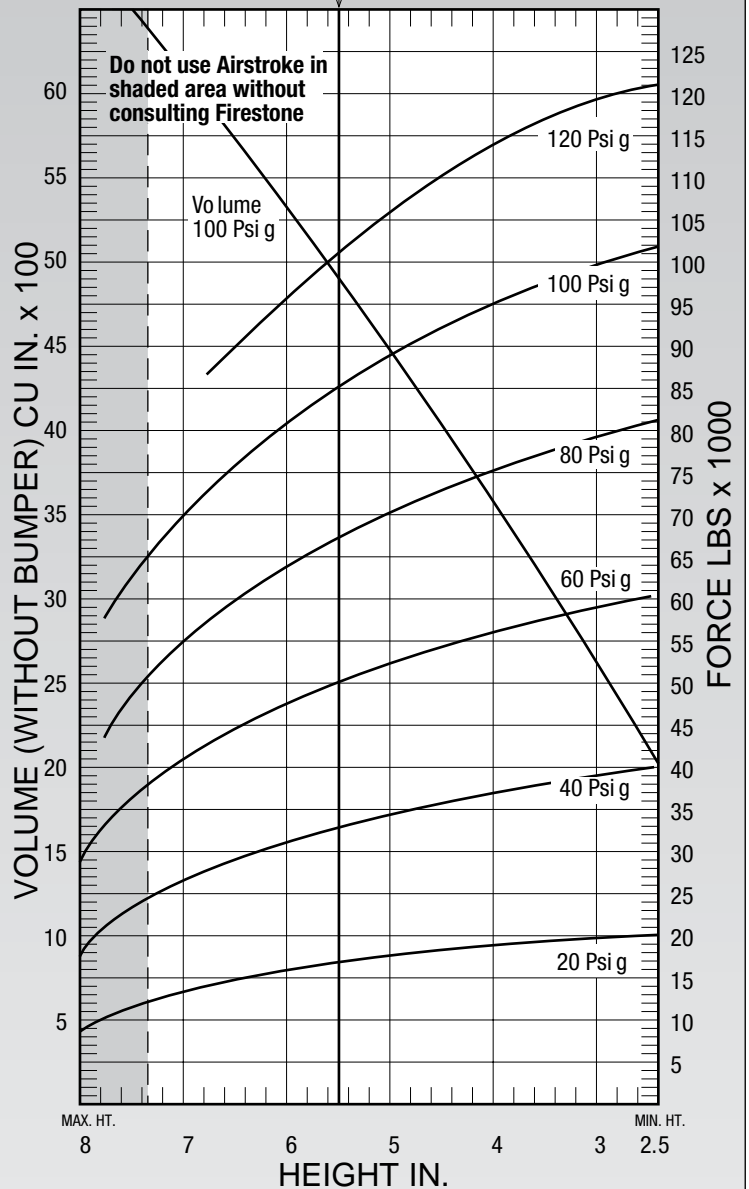

See page 12 for instructions on how to use chart.

Dynamic Characteristics at 5.5 in. Design Height (Required for Airmount isolator design only)				
Volume @ 100 PSIG = 4,914 in <sup>3</sup>			Natural Frequency	
Gage Pressure (PSIG)	Load (lbs.)	Spring Rate (lbs./in.)	CPM	HZ
40	32,860	14,220	123	2.06
60	50,290	19,969	118	1.97
80	67,690	26,697	118	1.96
100	85,200	32,491	116	1.93

Force Table (Use for Airstroke™ actuator design)						
Assembly Height (in.)	Volume @ 100 PSIG (in <sup>3</sup> )	Pounds Force				
		@20 PSIG	@40 PSIG	@60 PSIG	@80 PSIG	@100 PSIG
7.0	6,134	13,470	26,890	41,610	55,830	70,860
6.0	5,337	15,720	31,220	47,920	64,170	80,890
5.0	4,471	17,450	34,310	52,370	70,980	89,140
4.0	3,532	18,810	36,970	56,050	76,330	95,540
3.0	2,542	19,940	39,470	59,360	80,110	100,050