

Description		Assembly Order No.
Style 1T19L-11	Blind nuts, 1/4 NPT	W01-358-9155
	Blind nuts, 1/4 NPT, bumper	W01-358-9156
Two Ply Bellows	Blind nuts, 3/4 NPT	W01-358-9153
	Blind nuts, 3/4 NPT, bumper	W01-358-2132
	Countersunk steel bead ring 1 3/4 bolts, nuts, washers	W01-358-9162
Assembly weight.....		20.4 lbs.

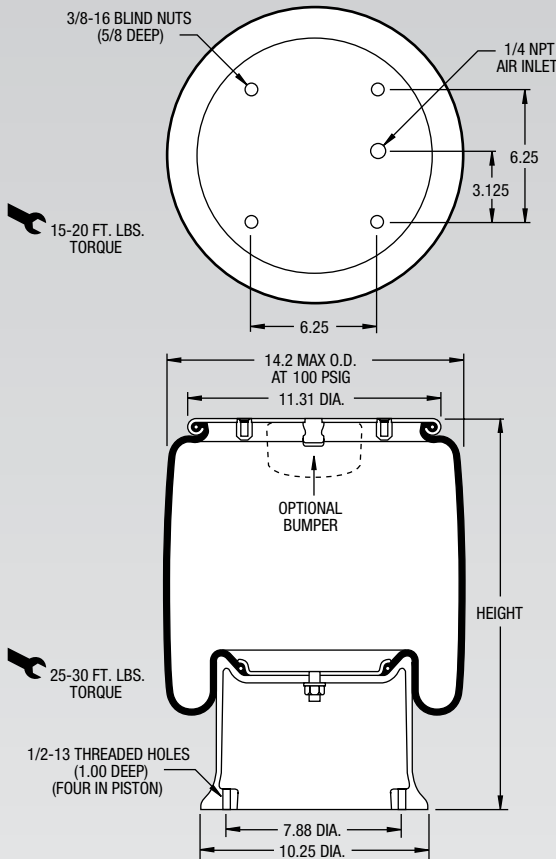

NOTE: Bellows will not compress properly with less than 20 PSIG internal pressure.

NOTE: A bead plate part is shown. This part is also available with a bead ring. Bolts are not included. See pages 8-10 for explanation.

Dynamic Characteristics at 17.0 in. Design Height (Required for Airmount isolator design only)				
Volume @ 100 PSIG = 1,337 in ³			Natural Frequency	
Gage Pressure (PSIG)	Load (lbs.)	Spring Rate (lbs./in.)	CPM	HZ
40	3,411	428	67	1.12
60	5,151	602	64	1.07
80	6,911	765	63	1.05
100	8,711	927	61	1.02

CONSULT FIRESTONE BEFORE USING AS AIRMOUNT

RECOMMENDED AIRMOUNT DESIGN HEIGHT 17.0 INCHES

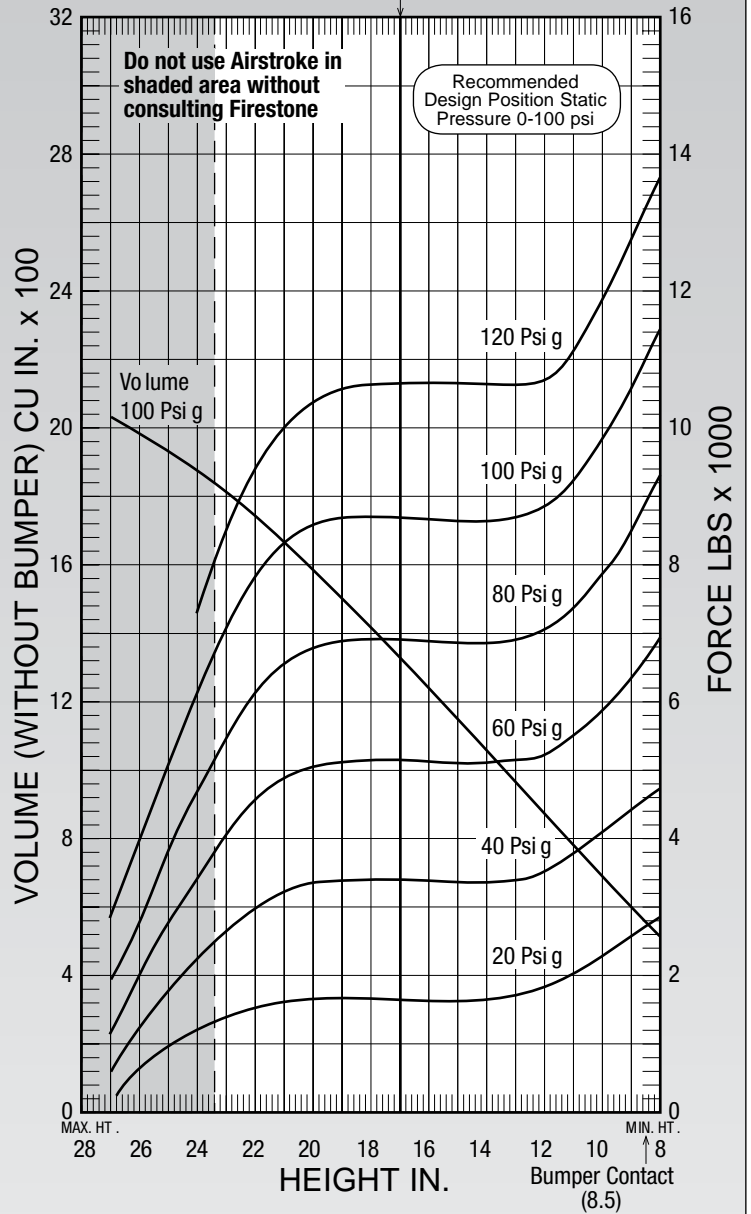

See page 12 for instructions on how to use chart.

Force Table (Use for Airstroke™ actuator design)						
Assembly Height (in.)	Volume @ 100 PSIG (in ³)	Pounds Force				
		@20 PSIG	@40 PSIG	@60 PSIG	@80 PSIG	@100 PSIG
20.0	1,597	1,650	3,341	5,068	6,843	8,619
18.0	1,427	1,650	3,411	5,151	6,911	8,711
16.0	1,247	1,650	3,411	5,151	6,911	8,711
14.0	1,060	1,650	3,411	5,151	6,911	8,711
12.0	872	1,830	3,510	5,278	7,101	8,903
10.0	688	2,283	4,100	5,960	7,946	9,911