

BELLOWS 10" x 2

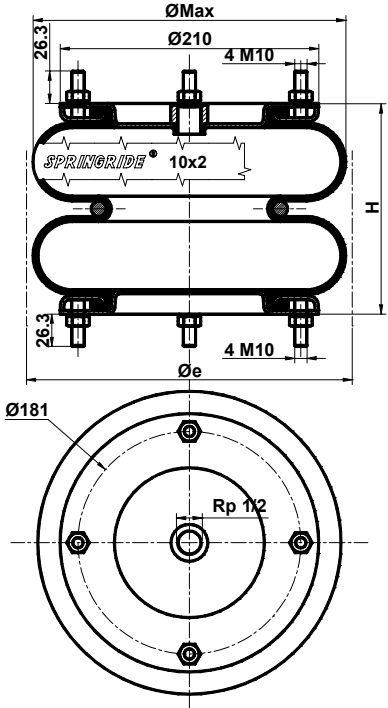

ASSEMBLED WITH 8 NUTS Hu10 AND 8 WASHERS GROWER WZ10.
FASTENING TORQUE 25 Nm

Heights (mm) (H)			Stroke (mm)
Maximum	Minimum	Design	
300	75	170	225
Diameters (mm)			Weight (kg)
Ø MAX	Overall		
270	300		4.9

Rubber Bellow	Features	Part Numbers
Standard	-Rubber Only	SP 255
-40 to 70°C	-Assembled Bellows	SP1538
Butyl	-Rubber Only	SP1150
-25 to 90°C	-Assembled Bellows	SP1660
Epichlore	-Rubber Only	SP2168
-20 to 115°C	-Assembled Bellows	SP2590

VOLUME V (dm³) at 6 bar

LOAD (daN)

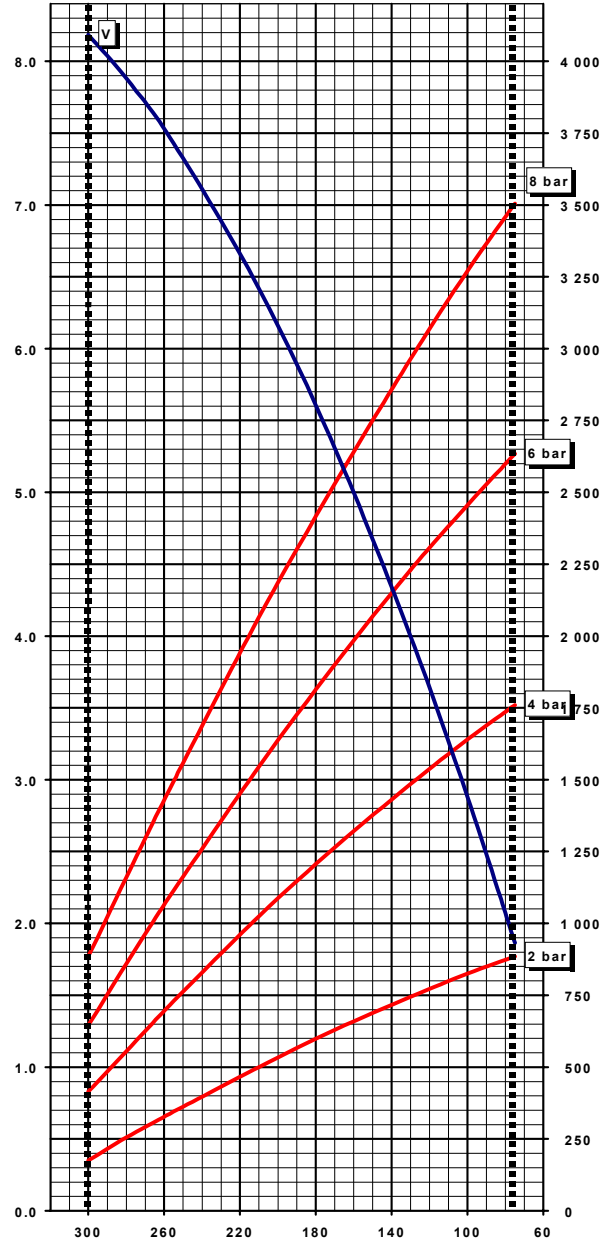

HEIGHT (mm)

- Indicative value of force required to reach minimum height at atmospheric pressure : 9 daN

- Maximum pressure : 8 bar

- The datas presented on this document are liable to evolution and don't constitute a commitment from DUNLOP AIRSPRINGS (see page 5-7).

BELLOWS 10" x 2

FOR USE AS A PNEUMATIC ACTUATOR

CHARACTERISTICS IN STATIC CONDITION				
HEIGHT (mm)	LOAD (daN)			
	Pressure 2 bar	Pressure 4 bar	Pressure 6 bar	Pressure 8 bar
75	885	1760	2635	3505
100	825	1640	2455	3270
130	745	1485	2230	2965
170	630	1265	1900	2530
210	500	1025	1545	2065
250	365	765	1165	1560
300	175	415	645	885

ANGULAR CAPABILITY

Maximum (α)	For H between	
	H mini (mm)	H maxi (mm)
10°	95	260
15°	115	250
20°	135	245
25°	155	235

OUT OF ALIGNMENT

Maximum (A)	For H between	
	H mini (mm)	H maxi (mm)
10	105	280
20	125	275
30	145	265
40	170	250

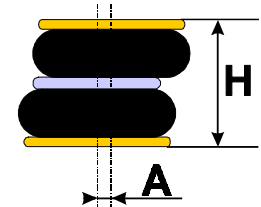
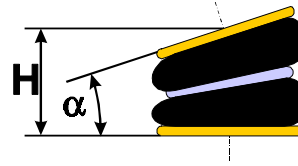

- Airsprings must not be pressurised unless they are restricted by an outside frame or by a suitable load.
- Strokes must be limited by the direct use of bump stops or external stops.
- When stacking airsprings, special cares must be taken to ensure the airsprings are guided and fixed.
- An Airspring is a single acting air actuator and must not be used below atmospheric pressure.
- Please check the over-pressure in case of quick compression.
- The datas presented on this document are liable to evolution and don't constitute a commitment from DUNLOP AIRSPRINGS (see page 5-7).

FOR USE AS AN ISOLATOR

DYNAMIC CHARACTERISTICS AT H= 220 mm *				
	Pressure 2 bar	Pressure 4 bar	Pressure 6 bar	Pressure 8 bar
LOAD (daN)	470	960	1455	
VOLUME (dm³)	6.22	6.44	6.67	
STIFFNESS (daN/cm)	70.2	125.4	178.8	
NATURAL FREQUENCY (Hz)	1.93	1.80	1.75	
ISOLATION RATE at 10 Hz	96.1%	96.6%	96.8%	

- Isolation rate is given by the formula :

$$I = 1 - \frac{1}{\left(\frac{f_e}{f_n}\right)^2 - 1}$$

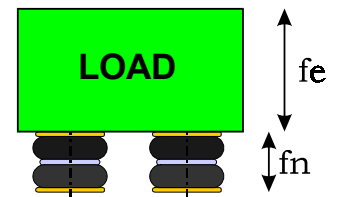

fe = Exciting frequency (Hz)
fn = Airspring natural frequency (Hz)

* Recommended height for better isolation.