

FS 70-9

CONTI® Single Convolution Air Spring

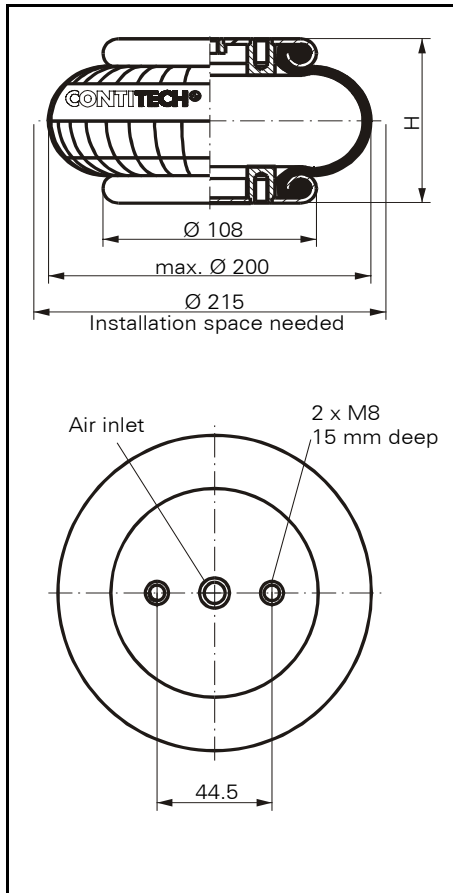

FS 70-9

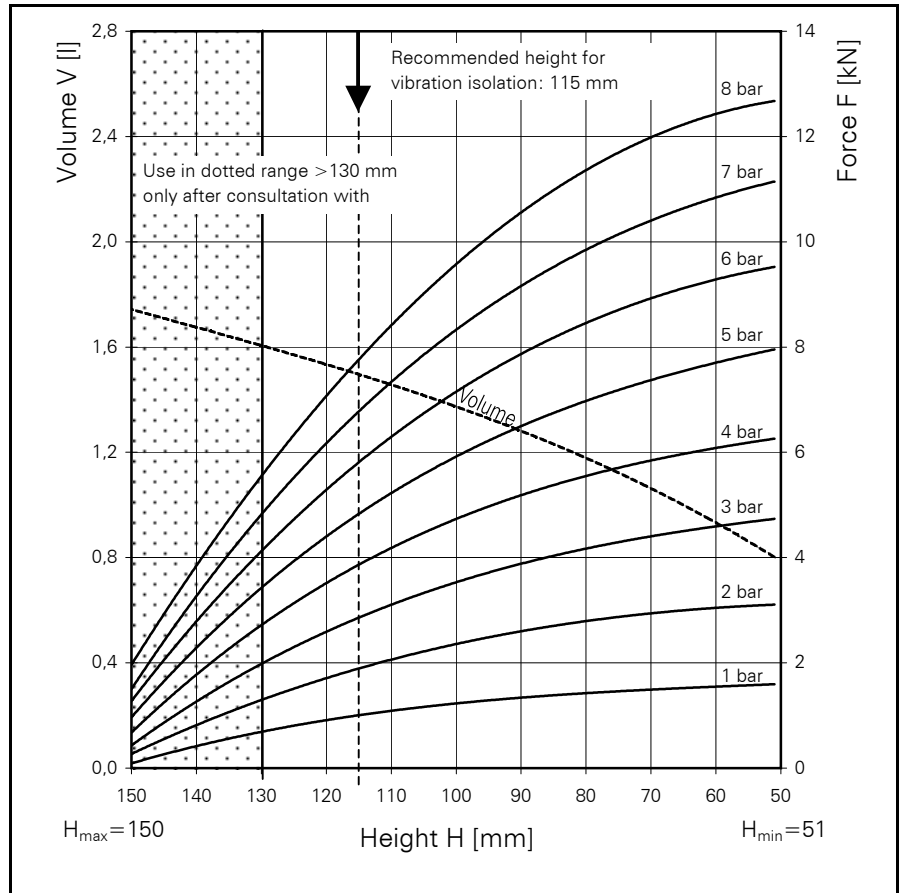

Force-height diagram

Purchase order data

Type	Order No.
Rubber bellows only	62168
With clamped plates	on request
G 1/4 air inlet	

Additional types on request

Technical data

Min. pressure	0 bar
Return force to min. height	≤ 200 N
Overall weight with clamped plates	1.4 kg

Vibration isolation - dynamic characteristic values

Design height H: recommended 115mm, minimum 100mm

Pressure p [bar]	3	4	5	6	7	8	Vol V [l]
Force (Load) [kN]	2.9	3.8	4.8	5.8	6.8	7.7	
Spring rate [N/cm]	855	1110	1340	1590	1840	2050	
Natural frequency [Hz]	2.8	2.7	2.7	2.6	2.6	2.6	

Pneumatic application - static characteristic values

Force F [kN]

Pressure p [bar]	3	4	5	6	7	8	Vol.[l]		
Height H [mm]	120	2.6	3.5	4.4	5.3	6.2		7.2	1.54
	110	3.1	4.2	5.2	6.3	7.4		8.5	1.46
	100	3.5	4.7	5.9	7.2	8.3		9.6	1.38
	90	3.9	5.2	6.5	7.9	9.2		10.5	1.27
	80	4.2	5.6	7.0	8.5	9.8		11.3	1.18
	70	4.5	5.8	7.4	9.0	10.4		12.0	1.07



Service instructions
 M 8 = 25 Nm
 G 1/4 = 25 Nm